

# SR130 | SR150



## SKID STEER LOADERS SPEC SHEET



### PERFORMANCE SPECS

	SR130	SR150
Rated operating capacity 50% (kg) _____	590	680
ROC with counterweights 50% (kg) _____	635	725
Tipping load (kg) _____	1179	1361
Bucket cylinder breakout force (kN) _____		18.6
Boom geometry _____		Radial

### ENGINE

Engine model _____		ISM
Emission level _____		Tier 3
Displacement (l) _____		2.2
Horsepower (hp) _____	49	60
(@ rpm) _____	2800	2800
Peak torque (Nm) _____	143	171
(@ rpm) _____	1800	1800
Aspiration type _____	Natural	Turbo

### TRAVEL SPEED

Max. travel speed (km/h) _____	10.8
--------------------------------	------

### HYDRAULIC SYSTEM

Pump flow (lpm) _____	59
Relief pressure (bar) _____	207

### WEIGHTS

Operating weight (kg) _____	2300	2430
Shipping weight (kg) _____	2160	2300

### SERVICE CAPACITY

Fuel tank (l) _____	60.5
---------------------	------

**GENERAL DIMENSIONS**

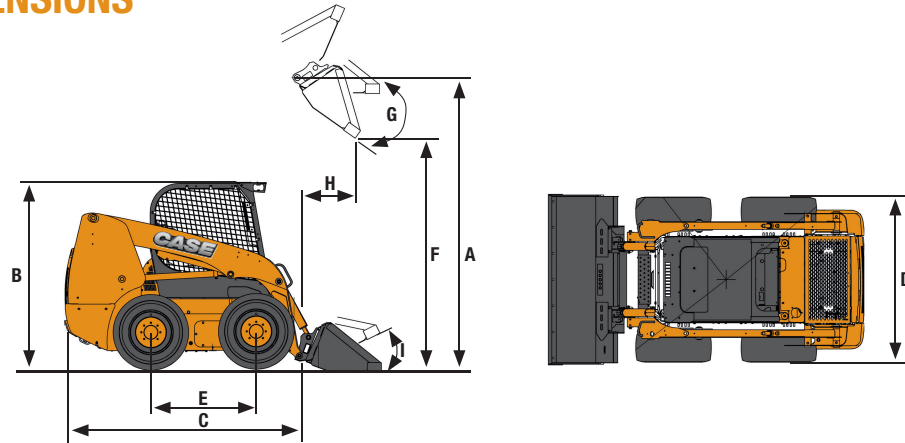

		SR130	SR150
A	Height to bucket hinge pin	mm	2845
B	Height to top of ROPS	mm	1919
C	Length without attachment	mm	2435
D	Overall width	mm	1518
E	Wheelbase	mm	941
F	Dump height *	mm	2246
G	Dump angle	°	40
H	Dump reach @ max height	mm	469
I	Rollback angle (bucket on ground)	°	26

\* With D&F Bucket

**MANY ATTACHMENTS MEAN MANY BUSINESS OPPORTUNITIES**



**BUCKETS**

Tailor made bucket for a wide range of applications

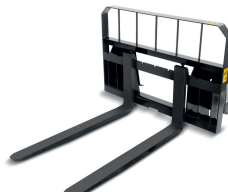

**PALLET FORKS**

Easy handling of palletized loads

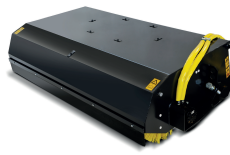

**BROOM BUCKET**

Efficient surfaces sweeping



**HAMMERS**

For concrete demolition, Trenching and general excavation work



**AUGERS**

For easy boring of holes in the ground

Check complete list of available attachments on the Parts & Service attachments catalogue

